



SecureLinx™ SLB Branch Office Manager



SecureLinx™

SecureLinx™ SLB Branch Office Manager Quick Start Guide



SecureLinX™ SLB Branch Office Manager

- Manages servers and distributed IT equipment at remote branch office locations with a single, space-saving appliance
- Integrates secure console management (8 serial ports), remote power management (4 power outlets), and an 8-port Ethernet switch into a 1U rack-mountable solution
- Compact design ideally suited to meet the unique needs of remote branch office environments
- Provides the highest levels of encryption and security to ensure data assets are protected
- Works seamlessly with SecureLinX Spider™ Distributed KVM (optional) for a complete all-in-one distributed IT management solution

SECURELINX™ SLB BRANCH OFFICE MANAGER QUICK START GUIDE TABLE OF CONTENTS

System Overview	2
What's in the Box	3
Connecting the SLB	4-6
Installing the SLB	7
IP Addressing	8
Configuring Network (IP) Settings	9-10
Logging in	11-12
Contact Information	13

SYSTEM OVERVIEW

The SecureLinux Branch Office Manager (SLB) enables system administrators to securely manage remote servers and IT infrastructure equipment over the Internet. This innovative device combines the capabilities of secure console management, remote power management, and an Ethernet switch into a 1U rack-mountable appliance.

The SLB is available in a 100-120 VAC output model (SLB088411-01) with NEMA 5-15R type outlets, and a 208-240 VAC output model (SLB088412-01) with IEC60320/C13 type outlets. Both models have (4) power outlets and allow power management and control (on/off/reboot) for the attached equipment using a simple web or command line interface. The SLB has (8) serial (RJ45) device ports used for console management. The pin-outs for these ports are Sun/Cisco compatible (*see diagram on page 6*) so in most cases a simple “rolled” adapter along with a standard Cat-5 cable can be used for the serial connection. See the adapter/cable list on the next page to find the appropriate one for your equipment.

The SLB also has a built-in 8-port unmanaged Ethernet switch for convenience and to help further reduce required rack space. Also two 10/100 Ethernet ports, a front panel serial console port (RJ45), and two 32-bit CardBus (PC card) slots to support storage cards or a PC Card modem for dial-in access. The list of supported cards is available on the Lantronix website.

Typical IT equipment that would be managed by the SLB are:

- Servers • Switches • Routers • UPS systems • PBX systems • Telecom equipment

This Quick Start Guide explains the basics of how to connect and set up the SLB to work on the network. For more detailed information, refer to the User Guide found on the documentation CD or on the Lantronix website: www.lantronix.com.

WHAT'S IN THE BOX

In addition to the SLB, the box contains this Quick Start Guide, a documentation CD, appropriate power inlet cord, and a starter kit of commonly used serial adapters and cables. A variety of power cord types and additional adapters are available separately. See the Lantronix website or product spec for accessory details.

Serial Adapters and Cables Included

Part Number	Description
200.2066A	Adapter: RJ45 to DB25M (DCE) for Sun with DB25 female
200.2067A	Adapter: RJ45 to DB25F (DCE) for Sun with DB25 male and some HP9000's
200.2069A	Adapter: RJ45 to DB9M (DCE) for SGI Onyx
200.2070A	Adapter: RJ45 to DB9F (DCE) for HP9000, SGI Origin, IBM RS6000, and PC-based Unix/Linux servers
ADP010104-01	Adapter: RJ45 Rolled serial, 0.1m (0.33 Ft.) for Cisco and Sun Netra
500-184-R	Cable: RJ45 to RJ45, Cat-5, .3m (1 Ft.)
200.0063	Cable: RJ45 to RJ45, Cat-5, 2m (6.6 Ft.)
500-153	Cable: RJ45 Loopback

Power Cords Included

Part Number	Description
SLPP12310-01 ₁	Inlet cord: IEC60320/C19 to NEMA 5-15P (15A), 8 Ft.
SLPP12810-01 ₂	Inlet cord: IEC60320/C19 to Schuko (EU), 8 Ft.
SLPP12910-01 ₂	Inlet cord: IEC60320/C19 to BS1363 (UK), 8 Ft.
SLPP12A08-01 ₂	Inlet cord: IEC60320/C19 to AS 3112 (AUS/NZ), 8 Ft.

₁ Included with the 110V model. ₂ Included with the 220V model.

(See www.lantronix.com for additional Inlet Power Cords available.)

Not Included – Available Separately

Part Number	Description
SLPP41107-01	Outlet cord set for the 220 VAC model: IEC60320/C13 to IEC60320/C14, pkg. of 4, 6 Ft.
500-137	Cable: RJ45 to RJ45, Rolled serial, 3m (9.8 Ft.)
56KMODEMCARD-02	Modem: PC card v.92, RoHS
200.2073	Adapter: RJ45 to DB25M (DCE) for external modems

CONNECTING THE SLB

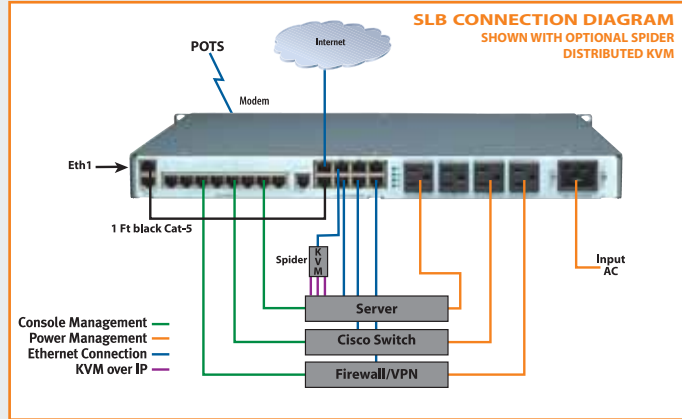

The SLB connects between a server or a piece of IT equipment and an IP network or the Internet. Once installed on the IP network, a remote user connects to the SLB using a secure web browser (HTTPS/SSL), Secure Shell (SSH), or Telnet session. If a modem is installed in the SLB, dial-in access is possible in the event that the IP network is unavailable. Once connected, the user has access to the server or IT equipment's command line interface (CLI) via the console port to perform maintenance or management tasks. If the equipment is connected to one of the SLB power outlets, then (on/off/reboot) power control is possible.

CONNECTING THE SLB CONTINUED...

The integrated 8-port Ethernet switch allows for quick and easy deployment of your servers and IT equipment. Just connect the Ethernet switch to the IP network /Internet, and then connect the SLB (Ethernet port #1) to the switch using the included (1 ft black) network Cat-5 cable. Connect additional IT equipment to the switch such as servers, switches, routers, firewall, VPN, UPS, or a Spider(s) for total network connectivity.

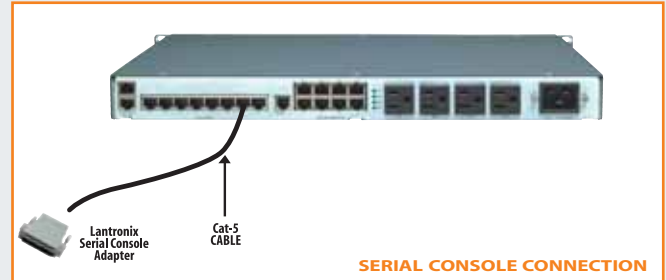

The front panel console port allows a dumb terminal or PC with terminal emulation software to locally access management functions and connected serial console devices. The device ports allow simple connections to serial devices using adapters and a standard Cat-5 cable. Connect one end of the Cat-5 cable to the device port, and the other end to an adapter that attaches to the serial console of the target system.

CONNECTING THE SLB CONTINUED

For example, to connect a PC to the device port of the SLB, you only need the female DB9 adapter (Part #200.2070A) and a standard Cat-5 cable, both of which are supplied with the SLB.

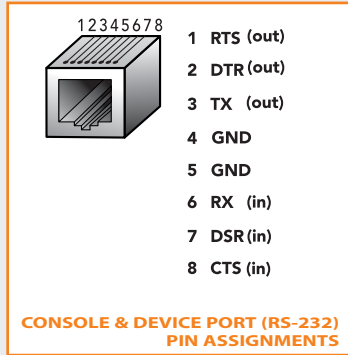

The default communication parameters for the device ports and the console port are:

- 9600 baud
- 8 data bits
- No parity
- 1 stop bit
- No flow control

The power outlets allow your equipment to use the SLB as its power source. Once connected you can remotely and securely control the state of each outlet (on/off/reboot).

INSTALLING THE SLB

1. Install the unit in a 19-inch rack if desirable.
Warning: Be careful not to block the air vents on the sides of the unit. If you mount it in an enclosed rack, we recommend that the rack have a ventilation fan.
2. Connect the SLB directly to the network through the top Ethernet port #1 or route through the integrated 8-port Ethernet switch (see connection diagram and instructions on page 4).
3. Connect up to eight serial console devices to the numbered device ports on the back of the unit using the appropriate cables and adapters.
4. To manage a device's power, plug its power cord into one of the four power outlets.
5. Install any PC cards you intend to use (optional). If you install a modem card, connect it to the phone line.
6. Attach the supplied power cord to the AC input connector and apply power.
7. Wait about a minute and a half for the boot process to end. When the boot process ends, the status of each power outlet displays on the LCD display. Detected faults or process messages may also display.

IP ADDRESSING

Both of the SLB network ports (Eth1 and Eth2) default to DHCP-assigned IP addresses. If you want to assign a different IP address, it must be within a valid range, unique to your network, and with the same subnet mask as your workstation.

To configure the SLB, you need the following information:

IP address (if not already assigned): _____ . _____ . _____ . _____

Subnet mask (if not already assigned): _____ . _____ . _____ . _____

Gateway: _____ . _____ . _____ . _____

DNS: _____ . _____ . _____ . _____

CONFIGURING NETWORK (IP) SETTINGS

The fastest way to set basic network parameters is by using the front panel keypad and display.

Note: If you prefer, you can get started by following a Quick Setup script on the command line interface using Telnet or SSH, or by connecting a terminal directly to the console (RS-232) port. The web page interface also provides a Quick Setup page.

See *Quick Setup* in the User Guide for instructions.

- Use the **right** and **left arrow** buttons to navigate from one option to another.
- Use the **up** and **down arrow** buttons to navigate between parameters within an option or to increase or decrease a numerical value.
- Use the **Enter** button in the center to enter or exit editing mode and to save changes.

Note: If no buttons are pressed for 30 seconds, the front panel display times out without accepting unsaved changes and returns to displaying the hostname and clock.

For example, to change the IP settings:

1. Press the **right arrow** button to display the **Network Settings** option and the current IP address.
2. Press the **Enter** button to go into editing mode.
3. Use the **up** and **down arrow** buttons to increment or decrement the IP address indicated by the cursor.
4. Use the **right** and **left arrow** buttons to move to and change the remaining digits of the IP address. Press the **Enter** button to exit editing mode when finished.



CONFIGURING NETWORK (IP) SETTINGS CONTINUED

5. Press the **down arrow** button to display the **Subnet Mask** setting.
6. Edit the **Subnet Mask** in the same fashion as the IP address and press the **down arrow**.
7. Edit the **Gateway** and **DNS** settings.
8. Press the **down arrow** after the **DNS 3** setting to go to the **Save settings? Yes/No** prompt.
9. Select **Yes** at the prompt and press **Enter** to save changes.
Repeat steps 1-8 for the other options (console port and date/time).

Note: Another option, is to restore factory defaults. The default password for this action is 999999. See the SLB User Guide for more details.

After you save the values for your console manager, changes take effect immediately.

LOGGING IN TO THE SLB WEB PAGE

This section includes instructions for accessing both the web page and the command line interfaces. You can use either method to configure all parameters.

To log in to the SLB web page:

1. Open a web browser (Netscape 8.1 Navigator and later or Internet 6.0 Explorer and later).
2. In the URL field, type **https://** followed by the IP address of your SLC.
3. At the first login, enter **sysadmin** (all lower case) as the user and **PASS** (all upper case), the default factory password.



The first time you log in, the SLC Quick Setup page displays. Subsequent logins display the SLC Home Page. (To display Quick Setup again, click the **Quick Setup** tab.)

4. Do one of the following:
 - To bypass the Quick Setup page and go directly to configuring the SLC, click the **Accept default Quick Setup settings** checkbox and click **Apply**.
 - Update basic network parameters, if desired, and click **Apply**.

LOGGING IN TO THE COMMAND LINE INTERFACE

To access the command line interface

1. Do one of the following:
 - With a network connection, use a Telnet or SSH program to Telnet or SSH to **xx.xx.xx.xx** (the IP address in dot quad notation), and press **Enter**. You should be at the login prompt. **Note:** By default, Telnet is disabled. To enable Telnet, use the Services web page, a serial terminal connection, or an SSH connection.
 - With a serial terminal connection, when the command line displays, press **Enter**.
2. Enter **sysadmin** as the user name and press **Enter**.
3. Enter **PASS** as the password and press **Enter**. The first time you log in, the Quick Setup script opens automatically. Subsequent logins display the command prompt only. (To obtain the Quick Setup script again, use the `admin quicksetup` command.)
Note: Change the default password as soon as possible to prevent access by unauthorized personnel. Subsequent logins require the username **sysadmin** and the appropriate password to log in as system administrator.
4. If the Quick Setup script displays, update basic network parameters, as desired. Otherwise, just press **Enter** until the command prompt displays. By pressing **Enter**, you are accepting the current settings.

Notes:

- For general command line interface help, type `help command line`.
- For help with a specific command, type `help` followed by the command, for example, `help set network` or `help admin firmware`.

CONTACT INFORMATION

For questions and technical support, please check our online knowledge base at www.lantronix.com/support

Lantronix

15353 Barranca Parkway, Irvine, CA 92618, USA

Phone: (949) 453-3990 or Fax: (949) 453-3995

www.lantronix.com